



# Safety you can trust.



New with STRAUB-OPEN-FLEX

Manual

**straub**   
**the original**

an *OAliaxis* company

## **We connect safety with responsibility.**

### **Our experience – your guarantee.**

The name STRAUB is synonymous with expertise, quality and reliability. As an internationally renowned manufacturer of pipe joints, STRAUB not only invented the “original”, it also owns the patents on several outstanding features that still make the famous STRAUB pipe coupling the unquestioned leader in its class. Our unique pipe coupling concept is backed on 40 years of experience and continuous development, guaranteeing Swiss quality and value.



The installation of a STRAUB pipe joint is fast, simple and reliable. The compact product only has to be pushed over the pipe ends and tightened. Advice, training and documentation are part of our quality service, wherever our product is used. Being awarded the ISO 9001 Quality Assurance Certificate in 1995 confirms proven STRAUB quality. This fact has once again made us world pioneers in the area of progressive sealing pipe joints.

### **Our solution – your added value.**

Our total product and customer focus enables us to respond quickly and efficiently to our customers' most stringent requirements. There is no substitute for our experience. STRAUB invented the “original” and continues to refine and improve the design today. Pipe couplings are our only business – we are passionate about what we do.

You can rely on it: our solutions are your added value.



Besides, STRAUB is the first pipe coupling manufacturer supplying his products with a European “passport”. They meet the Pressure Equipment Directive 97/23 EC, Annexe VII. Register code 2002, 3989/P.

# Content



<b>The principle</b>	<b>4</b>
One Basic Concept	4
Two types of STRAUB couplings	4
Six Products	4
<b>Properties</b>	<b>5</b>
The progressive sealing effect	5
The progressive anchoring effect	5
<b>Benefits</b>	<b>5</b>
<b>STRAUB-METAL-GRIP</b>	<b>6</b>
Specifications	7–8
<b>STRAUB-GRIP-L</b>	<b>9</b>
Specifications	10–11
<b>STRAUB-PLAST-GRIP</b>	<b>12</b>
Specifications	13
<b>STRAUB-COMBI-GRIP</b>	<b>14</b>
Specifications	15
<b>STRAUB-FLEX</b>	<b>16</b>
Specifications	17–19
<b>STRAUB-OPEN-FLEX</b>	<b>20</b>
Specifications	21–23
<b>Options</b>	<b>24</b>
STRAUB-OPEN-FLEX GT	24
STRAUB-STEP-FLEX	24
STRAUB-FLAMSTOP	24
<b>Accessories</b>	<b>25</b>
Electrical conductivity clips	25
STRAUB-OPEN-FLEX installation tool	25
Torque wrench	25
Strip inserts	26
<b>Materialqualitäten von STRAUB-Rohr- kupplungen</b>	<b>26</b>
<b>Dimensions and minimum wall thickness</b>	<b>27</b>
<b>Fitting tolerances</b>	<b>28–29</b>
<b>Main range of application</b>	<b>30</b>
<b>Coupling selection chart</b>	<b>30</b>
<b>Suitable on different pipe materials</b>	<b>30</b>

## One basic concept



## Two types of STRAUB couplings

A unique technical principle: two basic types, but with innumerable applications.

Wherever pipes have to be joined together. That is the secret of STRAUB pipe joints. Their safety and reliability have been examined and certificated by public authorities, insurance companies, technical inspectorates and licensing institutions for all the major industrial sectors in most industrial countries.

STRAUB-GRIP



Pull out resistant

STRAUB-FLEX



Axially flexible



## Six products



**STRAUB-METAL-GRIP**

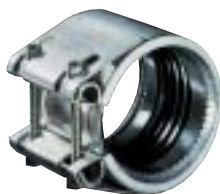

**STRAUB-GRIP-L**



**STRAUB-FLEX**



**STRAUB-COMBI-GRIP**



**STRAUB-PLAST-GRIP**



**STRAUB-OPEN-FLEX**

## Properties

### The progressive sealing effect

As the pressure in the pipe increases, so does the force on the sealing lips, due to the flow through the pressure equalisation channel.



STRAUB-FLEX



STRAUB-GRIP

### The progressive anchoring effect

As the axial loading on the pipe increases due to increased internal pressure or external influences, the teeth bite even deeper into the pipe to compensate. The penetration depth of the anchoring ring teeth under pressure is 0.1–0.3 mm.



STRAUB-GRIP



## Benefits

**System independence:** suitable for any pipe material

**Flexible pipe joint:** stress-free, compensates for tolerances

**Easy handling:** low weight, space-saving, no pipe-end preparation or special tools

**No heat or fire hazard:** can be installed in fire-risk or confined spaces without special equipment or permits

**Detachable and reusable:** short interruption times

**Damping properties:** noise, vibration, movements

**Economical:** labour-saving due to quick installation

## STRAUB-METAL-GRIP

### In a class by itself – for demanding applications

For building construction or civil engineering, water or waste water installations, power plants or industrial plants, shipbuilding/offshore or as a machinery component, the STRAUB-METAL-GRIP is the ultimate pull-out resistant pipe joint. STRAUB-METAL-GRIP also absorbs unexpected field stress and applies perfect for seismic retrofits.

Working pressure up to 67 bar  
Outside diameters 30.0 up to 609.6 mm  
Temperature range -30°C up to +100°C  
Example for order:  
STRAUB-METAL-GRIP 76.1, EPDM, SS

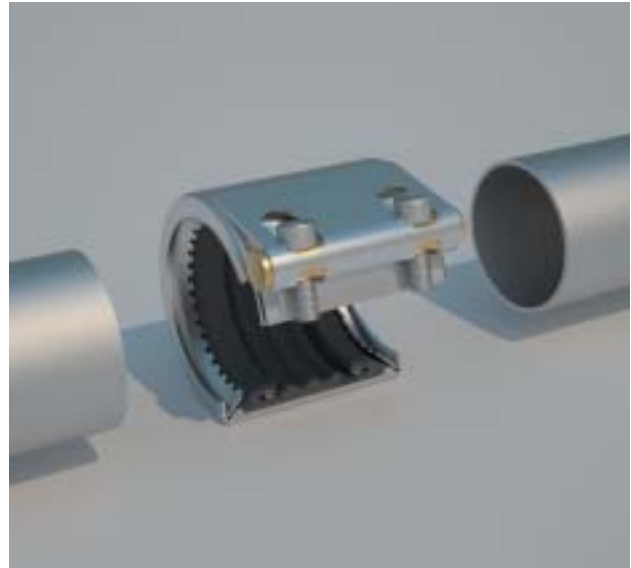

### Air conditioning in the city of Paris

Insulated carbon steel pipe with 12 bar operating pressure, 5°C medium temperature, STRAUB-METAL-GRIP 219.1 mm



Shock testing up to 200 g  
Four times safety factor  
Easy fitting

**Specification STRAUB-METAL-GRIP Ø 30.0 – 219.1 mm**

Components / Materials	W1	W2	W4	W5
Casing		AISI 304	AISI 304	
Screws		AISI 4135 <sup>o</sup>	AISI 316	
Bolts		AISI 12L 14, galvanized	AISI 304	
Anchoring ring		AISI 301	AISI 301	
Strip insert (option)		AISI 316 L / PVDF	AISI 316 L / PVDF	
Sealing sleeve	Temp.: -30°C up to +100°C			
<b>EPDM</b>	Medium: all qualities of water, waste water, air, solids and chemical products			
Sealing sleeve	Temp.: -20°C up to +80°C			
<b>NBR</b>	Medium: water, gas, oil, fuel and other hydrocarbons			

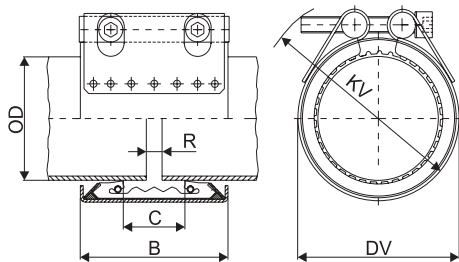

Pipe OD (mm)	Clamping range (mm)	Nominal pressure PN (bar)	Working pressure PS (bar)	Dimensional data				Setting gap between pipe ends R		Locking bolts		
				B (mm)	C (mm)	braced		without strip insert (mm)	with strip insert (mm)	torque rate (Nm)	allen head (mm)	thread M...
						DV (mm)	KV (mm)					
30.0	29.5 - 30.5	16	67	46/67	18	47	70	5	5 - 15	10	6	8
33.7	33.2 - 34.2	16	62	46/67	18	52	75	5	5 - 15	10	6	8
38.0	37.5 - 38.5	16	58	61	19	58	90	5	5 - 15	15	6	8
42.4	41.9 - 42.9	16	53	61	20	62	90	5	5 - 15	15	6	8
44.5	44.0 - 45.0	16	48	61	20	64	95	5	5 - 15	15	6	8
48.3	47.8 - 48.8	16	44	61	20	68	95	5	5 - 15	15	6	8
54.0	53.5 - 54.5	16	39	77	38	74	100	5	5 - 15	20	6	8
57.0	56.4 - 57.6	16	37	77	32	77	105	5 - 10	5 - 25	20	6	8
60.3	59.7 - 60.9	16	37	77	32	82	110	5 - 10	5 - 25	20	6	8
63.5	62.9 - 64.1	16	37	77	32	84	114	5 - 10	5 - 25	20	6	8
76.1	75.3 - 76.9	16	56	94	39	100	130	5 - 10	5 - 25	35	8	10
84.0	83.2 - 84.8	16	45	94	39	112	140	5 - 10	5 - 25	35	8	10
88.9	88.0 - 89.8	16	41	94	39	117	145	5 - 10	5 - 25	35	8	10
104.0	103.0 - 105.0	16	37	94	39	133	160	5 - 10	5 - 25	35	8	10
108.0	106.9 - 109.1	16	35	94	39	133	160	5 - 10	5 - 25	35	8	10
114.3	113.2 - 115.4	16	34	94	39	139	165	5 - 10	5 - 25	35	8	10
129.0	127.7 - 130.3	16	33	108	51	160	190	5 - 15	5 - 35	60	10	12
133.0	131.7 - 134.3	16	33	108	43	160	190	5 - 15	5 - 30	60	10	12
139.7	138.3 - 141.1	16	32	109	43	168	200	5 - 15	5 - 30	60	10	12
154.0	152.5 - 155.5	16	32	109	51	186	215	5 - 15	5 - 35	60	10	12
159.0	157.4 - 160.6	16	31	109	43	187	215	5 - 15	5 - 30	60	10	12
168.3	166.6 - 170.0	16	29	109	43	200	230	5 - 15	5 - 30	60	10	12
219.1	216.9 - 221.3	16	26	150	60	259	295	5 - 15	5 - 35	100	14	16

**Legend:**

- W1-W5 according to DIN Standard 86128 (ASTM F1476 / F1548, ISO/NP-15837 / 15838).
- PS: Working pressure considering the application loads. Contact factory for higher working pressure.
- PN: Nominal pressure, includes four times safety factor, for applications that require authorisation of classification societies (e.g. ABS, DNV, etc.).
- <sup>o</sup> Property class 12.9, Dacromet 500 (zinc-chromate with integrated lubricant).

**Remarks:**

- Follow fitting / disassembly instructions.
- Test pressure = 1,5 x PN / PS.
- The pressure values are valid on radial rigid carbon steel pipes under static loads (for minimum wall-thickness of pipe see p. 27 or contact factory).
- Weight of the pipe couplings see separate packing specifications.
- Strip insert is required when gap between pipe ends is excessive, in presence of swelling, vacuum/depression (suction line), or external pressure. Strip inserts are available, under separate order, at additional costs.

## Specification STRAUB-METAL-GRIP Ø 244.5 – 609.6 mm

Components / Materials	W1	W2	W4	W5
Casing	AISI 1024, hot-dip galv.			
Screws	AISI 4135 <sup>o</sup>			
Bolts	AISI 12L 14, galvanized			
Anchoring ring	AISI 301			
Strip insert (option)	AISI 316 L / PVDF			
Sealing sleeve	Temp.: -20°C up to +80°C			
<b>EPDM</b>	Medium: all qualities of water, waste water, air, solids and chemical products			
Sealing sleeve	Temp.: -20°C up to +80°C			
<b>NBR</b>	Medium: water, gas, oil, fuel and other hydrocarbons			

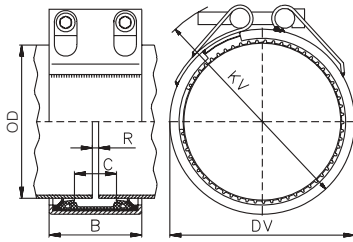

Pipe OD (mm)	Clamping range (mm)	Nominal pressure PN (bar)	Working pressure PS (bar)	Dimensional data				Setting gap between pipe ends R		Locking bolts		
				B (mm)	C (mm)	DV (mm)	KV (mm)	without strip insert (mm)	with strip insert (mm)	torque rate (Nm)	allen head (mm)	Gewinde thread
244.5	242.0 - 247.0	14	27									
267.0	264.5 - 269.5	12	24	148	67	312	365	180	17	20		
273.0	270.5 - 275.5	12	21	148	67	318	370	180	17	20		
323.9	320.5 - 327.0	10	18	148	67	369	420	230	17	20		
355.6	352.0 - 359.0	8	17	148	67	401	450	230	17	20		
406.4	402.5 - 410.5	8	14	148	67	451	500	230	17	20		
457.2	452.5 - 462.0	6	8	148	67	502	550	250	17	20		
508.0	503.0 - 513.0	5	6	148	67	553	600	250	17	20		
558.8	554.0 - 564.0	4.5	6	148	67	604	650	300	17	20		
609.6	604.5 - 614.5	4	5	148	67	655	700	300	17	20		

### Legend:

- W1-W5 according to DIN Standard 86128 (ASTM F1476 / F1548, ISO/NP-15837 / 15838).
- PS: Working pressure considering the application loads. Contact factory for higher working pressure.
- PN: Nominal pressure, includes four times safety factor, for applications that require authorisation of classification societies (e.g. ABS, DNV, etc.).
- <sup>o</sup> Property class 12.9, Dacromet 500 (zinc-chromate with integrated lubricant).

### Remarks:

- Follow fitting / disassembly instructions.
- Test pressure = 1,5 x PN / PS.
- The pressure values are valid on radial rigid carbon steel pipes under static loads (for minimum wall-thickness of pipe see p. 26 or contact factory).
- Weight of the pipe couplings see separate packing specifications.
- Strip insert is required when gap between pipe ends is excessive, in presence of swelling, vacuum/depression (suction line), or external pressure. Strip inserts are available, under separate order, at additional costs.

## STRAUB-GRIP-L

### Standard duty – for industrial plant construction up to 80°C

STRAUB-GRIP-L is the light standard coupling series of STRAUB. It is suitable particularly for lighter pipes within the lower pressure range. For shipbuilding, water and waste water treatment plants, industrial process pipe-work and many other applications. Whether pressure or suction lines, all piping systems are installed quickly, safely and economically with STRAUB-GRIP-L. A special advantage is the light weight and the one screw on the small diameters.

Working pressure up to 46 bar  
 Outside diameters 26.9 up to 609.6 mm  
 Temperature range -20°C up to +80°C  
 100% Stainless Steel Construction  
 Example for order:  
 STRAUB-GRIP-L 273.0, EPDM, SS

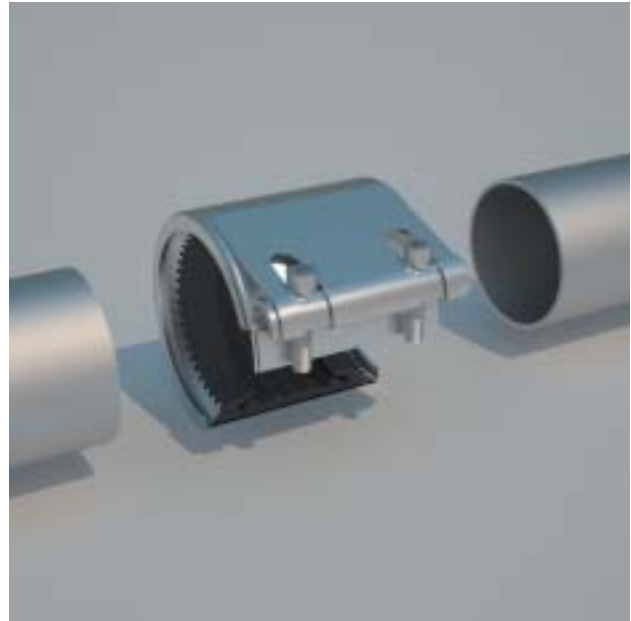

### Fast ferry “Corsaire 6000” STRAUB-GRIP-L at CuNiFe sea water system

On average 3000 couplings per ship in diameters 48.3–219.1 mm:

**Weight savings in comparison to flange:  
 24 Tons**

**Weight savings in comparison to other couplings:  
 2.1 Tons**

**Benefits:**  
 More payload  
 Lower transport costs  
 Easy fitting



## Specification STRAUB-GRIP-L Ø 26.9 – 219.1 mm

Components / Materials	W1	W2	W4	W5
Casing				AISI 316 Ti
Screws				AISI 316 L
U-bolts				AISI 316 Ti
Anchoring ring				AISI 301
Strip insert (option)				AISI 316 L / PVDF / HDPE
Sealing sleeve	Temp.: -20°C up to +80°C			
<b>EPDM</b>	Medium: all qualities of water, waste water, air solids and chemical products			
Sealing sleeve	Temp.: -20°C up to +80°C			
<b>NBR</b>	Medium: water, gas, oil, fuel and other hydrocarbons			
Sealing sleeve	Temp.: -20°C up to +180°C			
<b>VITON A'</b>	Medium: ozone, oxygen, acids, gas, oil and fuel (only with strip insert)			

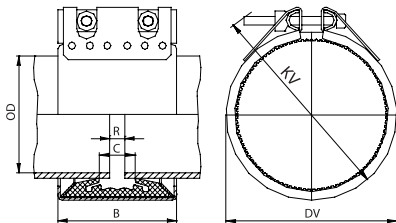

Pipe OD (mm)	Clamping range (mm)	Nominal pressure PN (bar)	Working pressure PS (bar)	Dimensional data				Setting gap between pipe ends R		Locking bolts		
				B (mm)	C (mm)	DV (mm)	KV (mm)	without	with	torque rate (Nm)	allen head (mm)	thread M...
26.9	26.4 - 27.4	16	46					46	19			
30.0	29.5 - 30.5	16	42	46	17	47	75	5	5	7.5	5	6
33.7	33.2 - 34.2	16	38	46	17	51	75	5	5	7.5	5	6
38.0	37.5 - 38.5	16	33	61	25	57	90	5	5 - 10	15	6	8
42.4	41.9 - 42.9	16	30	61	25	62	95	5	5 - 10	15	6	8
44.5	44.0 - 45.0	16	33	61	25	64	95	5	5 - 10	15	6	8
48.3 <sup>1</sup>	47.8 - 48.8	16	30	61	25	67	100	5	5 - 10	15	6	8
54.0	53.5 - 54.5	16	20	76	37	76	105	5 - 10	5 - 15	15	6	8
57.0	56.4 - 57.6	16	18	76	37	76	105	5 - 10	5 - 15	15	6	8
60.3 <sup>1</sup>	59.7 - 60.9	16	22	76	37	79	110	5 - 10	5 - 15	15	6	8
66.6	64.9 - 67.3	16	34	95	35	87	126	5 - 10	5 - 15	20	6	8
70.0	68.9 - 70.7	16	32	95	36	92	131	5 - 10	5 - 15	20	6	8
73.0 <sup>1</sup>	72.3 - 73.7	16	31	95	41	96	142	5 - 10	5 - 25	20	6	8
76.1 <sup>1</sup>	75.3 - 76.9	16	31	95	41	98	142	5 - 10	5 - 25	20	6	8
79.5	78.7 - 80.3	16	28	95	35	100	142	5 - 10	5 - 15	20	6	8
84.0	83.2 - 84.8	16	26	95	35	112	152	5 - 10	5 - 15	20	6	8
88.9 <sup>1</sup>	88.0 - 89.8	16	22	95	41	111	157	5 - 10	5 - 25	20	6	8
100.6	99.6 - 101.6	16	22	95	35	129	172	5 - 10	5 - 15	25	6	8
101.6	100.6 - 102.6	16	22	95	35	130	172	5 - 10	5 - 15	25	6	8
104.0	103.0 - 105.0	16	22	95	35	132	172	5 - 10	5 - 15	25	6	8
104.8	103.8 - 105.8	16	22	95	35	133	172	5 - 10	5 - 15	25	6	8
108.0	106.9 - 109.1	16	21	95	41	130	172	5 - 10	5 - 25	25	6	8
114.3 <sup>1</sup>	113.2 - 115.4	16	16	95	41	136	177	5 - 10	5 - 25	25	6	8
127.0	125.7 - 128.3	16	19	110	54	151	195	5 - 10	5 - 35	40	8	10
129.0	127.7 - 130.3	16	19	110	54	153	195	5 - 10	5 - 35	40	8	10
130.2	128.9 - 131.5	16	19	110	54	154	200	5 - 10	5 - 35	40	8	10
133.0	131.7 - 134.3	16	19	110	54	157	200	5 - 10	5 - 35	40	8	10
139.7	138.3 - 141.1	16	16	110	54	164	210	5 - 10	5 - 35	40	8	10
141.3	139.9 - 142.7	16	16	110	54	166	210	5 - 10	5 - 35	40	8	10
154.0	152.5 - 155.5	13	16	110	48	184	225	5 - 10	5 - 30	40	8	10
159.0	157.4 - 160.6	13	16	110	54	183	225	5 - 10	5 - 35	40	8	10
168.3	166.6 - 170.0	13	16	110	54	192	230	5 - 10	5 - 35	40	8	10
219.1	216.9 - 221.3	10	16	142	80	250	295	5 - 10	5 - 35	60	10	12

Specification STRAUB-GRIP-L Ø 180.0 – 609.6 mm

Components / Materials	W1	W2	W4	W5
Casing		AISI 304/316 Ti		AISI 316 Ti
Screws		AISI 4135 <sup>o</sup>		AISI 316 L
Bolts		AISI 12L 14, galvanized		AISI 316 L
Anchoring ring		AISI 301		AISI 301
Strip insert (option)		AISI 316 L / HDPE		AISI 316 L / HDPE
Sealing sleeve	Temp.: -20°C up to +80°C			
<b>EPDM</b>	Medium: all qualities of water, waste water, air, solids and chemical products			
Sealing sleeve	Temp.: -20°C up to +80°C			
<b>NBR</b>	Medium: water, gas, oil, fuel and other hydrocarbons			

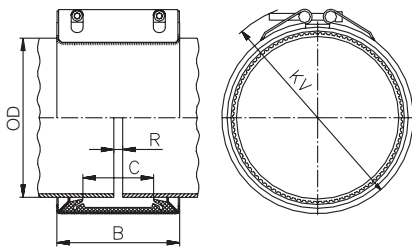

Pipe OD (mm)	Clamping range (mm)	Nominal pressure PN (bar)	Working pressure PS (bar)	Dimensional data				Setting gap between pipe ends R		Locking bolts		
				B (mm)	C (mm)	braced DV (mm)   KV (mm)		without strip insert (mm)	with strip insert (mm)	torque rate (Nm)	allen head (mm)	thread M...
180.0	178.0 - 182.0	-	16	141	80	205	255			50	10	12
193.7	192.0 - 195.5	-	16	141	80	224	270			50	10	12
200.0	198.0 - 202.0	-	15	141	80	230	275			50	10	12
204.0	202.0 - 206.0	-	14	141	80	234	280			50	10	12
206.0 <sup>o</sup>	204.0 - 208.0	-	14	141	80	234	280			50	10	12
244.5	242.0 - 247.0	5.5	9	141	80	275	320			50	10	12
250.0	247.5 - 252.5	5.5	9	141	80	280	325			50	10	12
254.0	251.5 - 256.5	5.5	9	141	80	284	325			50	10	12
256.0 <sup>o</sup>	253.5 - 258.5	5.5	9	141	80	284	325			50	10	12
267.0	264.5 - 269.5	5	8	141	80	297	340			50	10	12
273.0	270.5 - 275.5	4	7	141	80	303	345	5 - 10	5 - 35	50	10	12
304.0	301.0 - 307.0	4	6	141	80	334	375			60	10	12
306.0 <sup>o</sup>	303.0 - 309.0	4	6	141	80	334	375			60	10	12
323.9	320.5 - 327.0	3	5	141	80	354	395			70	10	12
355.6	352.0 - 359.0	2.5	4	141	80	386	425			70	10	12
406.4	402.5 - 410.5	2	3	141	80	436	470			70	10	12
457.2	452.5 - 461.5	-	2	141	80	487	520			70	10	12
508.0	503.5 - 512.5	-	2	141	80	538	570			70	10	12
558.8	554.5 - 563.5	-	2	141	80	589	620			70	10	12
609.6	605.5 - 614.0	-	1	141	80	640	670			70	10	12

Legend:

- W1-W5 according to DIN Standard 86128 (ASTM F1476 / F1548, ISO/NP-15837 / 15838).
- PS: Working pressure considering the application loads.
- PN: Nominal pressure, includes four times safety factor, for applications that require authorisation of classification societies (e.g. ABS, DNV, etc.)
- <sup>o</sup> Property class 12.9, Dacromet 500 (zinc-chromate with integrated lubricant).
- <sup>o</sup> Standard pipe dimension for stainless steel (outer diameter related to the wall thickness). For minimum wall-thickness of pipe see p. 27 or contact factory.

Remarks:

- OD 26.9-60.3 mm with one screw.
- Follow fitting / disassembly instructions.
- Test pressure = 1,5 x PN / PS.
- Weight of the pipe couplings see separate packing specifications.
- Strip insert is required when gap between pipe ends is excessive, in presence of swelling, vacuum/depression (suction line), or external pressure. Strip inserts are available, under separate order, at additional costs.
- The pressure values are valid on radial rigid carbon steel pipes under static loads.

## STRAUB-PLAST-GRIP

### Universal – for plastic pipes

In the gas and water supply industries and in industrial pipeline construction: for vacuum or pressure pipes, and fitting to thick and thin-walled pipes. The STRAUB-PLAST-GRIP is the ideal way of connecting plastic pipes.



Potable Water Processing, Local authority of Savièse, Switzerland: Transportation line connected with STRAUB-PLAST-GRIP 110 mm.



### Stiffening rings STRAUB-PG

Typical for pipes made of HDPE materials are the deformation and thermal stretching characteristics. The material tends to flow under pressure and temperature influences. This process is largely dependent on time. **External radial loading on the pipe requires the insertion of a STRAUB internal stiffening ring (material AISI 316 L / DIN 1.4435).** This also inhibits the tendency of the plastic to flow over the course of time.

Stiffening rings are also requested for STRAUB-FLEX applications. Available for inner diameter 40 mm up to 315 mm. (One stiffening ring per pipe end).

Specification STRAUB-PLAST-GRIP Ø 40.0 – 250.0 mm

Components / Materials	W1	W2	W4	W5
Casing		AISI 304	AISI 304	
Screws		AISI 4135 <sup>o</sup>	AISI 316 / 316 L	
Bolts		AISI 12L 14, galvanized	AISI 304	
Anchoring ring		AISI 301	AISI 301	
Strip insert (option)		AISI 316 L / PVDF	AISI 316 L / PVDF	
Sealing sleeve	Temp.: < 160.0 mm = -30°C up to +100°C; > 160.0 mm = -20°C up to +80°C			
<b>EPDM</b>	Medium: all qualities of water, waste water, air, solids and chemical products			
Sealing sleeve	Temp.: -20°C up to +80°C			
<b>NBR</b>	Medium: water, gas, oil, fuel and other hydrocarbons			

STRAUB-PLAST-GRIP

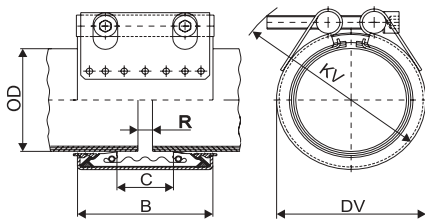

STRAUB-PLAST-GRIP (for plastic pipes)

Pipe OD (mm)	Clamping range (mm)	Working pressure PS (bar)	Dimensional data				Setting gap between pipe ends R without strip insert		Locking bolts		
			B (mm)	C (mm)	DV (mm)	KV (mm)	with strip insert (mm)	torque rate (Nm)	allen head (mm)	thread M...	
40.0	39.0 - 40.5	16	61	19	60	90	5	5 - 15	15	6	8
50.0	49.0 - 50.5	16	61	26	70	100	5	5 - 15	15	6	8
63.0	62.0 - 64.0	16	76	32	85	115	5 - 10	5 - 20	20	6	8
75.0	74.0 - 76.0	16	94	39	99	137	5 - 10	5 - 25	35	8	10
90.0	89.0 - 91.0	16	94	39	118	152	5 - 10	5 - 25	35	8	10
110.0	109.0 - 111.0	16	94	39	135	167	5 - 10	5 - 25	35	8	10
114.3	113.0 - 115.0	16	94	39	139	172	5 - 10	5 - 25	35	8	10
125.0	124.0 - 126.0	16	108	43	152	185	5 - 15	5 - 30	60	10	12
140.0	139.0 - 142.0	16	109	43	168	200	5 - 15	5 - 30	60	10	12
160.0	159.0 - 162.0	16	109	43	188	215	5 - 15	5 - 30	60	10	12
180.0	179.0 - 182.0	10	141	80	205	255	5 - 15	5 - 35	70	10	12
200.0	199.0 - 202.0	7	141	80	230	275	5 - 15	5 - 35	70	10	12
225.0	224.0 - 227.0	6	141	80	255	300	5 - 15	5 - 35	70	10	12
250.0	249.0 - 252.0	5	141	80	280	325	5 - 15	5 - 35	70	10	12

Legend:

– W1–W5 according to DIN Standard 86128 (ASTM F1476 / F1548, ISO/NP-15837 / 15838).

<sup>o</sup> Property class 12.9, Dacromet 500 (zinc-chromate with integrated lubricant).

Remarks:

- Follow fitting / disassembly instructions. Test pressure = 1,5 x PN / PS.
- For the installation of pipes made of HDPE and PP. **Stiffening rings STRAUB-PG required.**
- Weight of the pipe couplings see separate packing specifications.
- Strip insert is required when gap between pipe ends is excessive, in presence of swelling, vacuum/depression (suction line), or external pressure. Strip inserts are available, under separate order, at additional costs.

## STRAUB-COMBI-GRIP

### Practical – for transitions

The STRAUB-COMBI-GRIP ensures a perfect connection at transitions between plastic and metal pipes. The advanced technology and high-specification manufacture ensure increased safety and reliability wherever this coupling is used.

Joins plastic and metal pipes and compensates for differing outside diameters. Non-weathering and no pipe-end machining needed.



Fire safety system for alcohol tank farm in Switzerland  
Fire-fighting water pipes with transitions from stainless steel to plastic (PE).



Specification STRAUB-COMBI-GRIP Ø 40.0 – 250.0 mm

Components / Materials	W1	W2	W4	W5
Casing		AISI 304	AISI 304	
Screws		AISI 4135 <sup>0</sup>	AISI 316 / 316 L	
Bolts		AISI 12L 14, galvanized	AISI 304	
Anchoring ring		AISI 301	AISI 301	
Strip insert (option)		AISI 316 L / PVDF	AISI 316 L / PVDF	
Sealing sleeve	Temp.: < 160.0 mm = -30°C up to +100°C; > 160.0 mm = -20°C up to +80°C			
<b>EPDM</b>	Medium: all qualities of water, waste water, air, solids and chemical products			
Sealing sleeve	Temp.: -20°C up to +80°C			
<b>NBR</b>	Medium: water, gas, oil, fuel and other hydrocarbons			

STRAUB-COMBI-GRIP

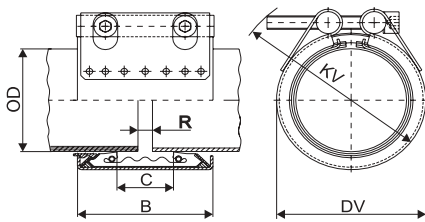

STRAUB-COMBI-GRIP (for transitions)

Pipe		Clamping range		Nominal pressure	Dimensional data				Setting gap between pipe ends R		Locking bolts		
plastic	metal	plastic	metal		PN	B	C	DV	KV	without strip insert	with strip insert	torque rate	allen head
(mm)	(mm)	(mm)	(mm)	(bar)	(mm)	(mm)	(mm)	(mm)	(mm)	(mm)	(Nm)	(mm)	M...
40.0	38.0	39.0 - 40.5	37.5 - 39.0	16	61	19	60	90	5	5 - 10	15	6	8
40.0	42.4	39.0 - 40.5	42.0 - 43.5	16	61	20	63	95	5	5 - 10	15	6	8
50.0	48.3	49.0 - 50.5	47.8 - 49.0	16	61	26	70	100	5	5 - 10	15	6	8
63.0	60.3	62.0 - 64.0	59.7 - 61.0	16	76	32	85	115	5 - 10	5 - 25	20	6	8
75.0	76.1	74.0 - 76.0	75.0 - 77.5	16	94	39	100	137	5 - 10	5 - 25	35	8	10
90.0	88.9	89.0 - 91.0	87.0 - 90.0	16	94	39	118	152	5 - 10	5 - 25	35	8	10
110.0	108.0	109.0 - 111.0	106.5 - 110.5	16	94	39	135	167	5 - 10	5 - 25	35	8	10
110.0	114.3	109.0 - 111.0	112.0 - 116.0	16	97	45	140	177	5 - 10	5 - 25	35	8	10
114.3	114.3	113.0 - 115.0	112.0 - 116.0	16	94	39	139	172	5 - 10	5 - 25	35	8	10
140.0	139.7	139.0 - 142.0	137.5 - 141.0	16	109	43	168	200	5 - 15	5 - 30	60	10	12
160.0	159.0	159.0 - 162.0	157.0 - 160.5	16	109	43	188	215	5 - 15	5 - 30	60	10	12
180.0	180.0	179.0 - 182.0	178.0 - 181.5	10	141	80	205	255	5 - 15	5 - 35	70	10	12
200.0	206.0 <sup>3</sup>	199.0 - 202.0	204.0 - 208.0	7	141	80	230	275	5 - 15	5 - 35	70	10	12
225.0	219.1	224.0 - 227.0	216.9 - 221.3	6	141	80	255	300	5 - 15	5 - 35	70	10	12
250.0	256.0 <sup>3</sup>	249.0 - 252.0	253.5 - 258.5	5	141	80	280	325	5 - 15	5 - 35	70	10	12

Legend:

- W1-W5 according to DIN Standard 86128 (ASTM F1476 / F1548, ISO/NP-15837 / 15838).
- <sup>0</sup> Property class 12.9, Dacromet 500 (zinc-chromate with integrated lubricant).
- <sup>3</sup> Standard pipe dimension for stainless steel (outer diameter related to the wall thickness). For minimum wall-thickness of pipe see p. 27 or contact factory.

Remarks:

- Follow fitting / disassembly instructions. Test pressure = 1,5 x PN / PS.
- For the installation of pipes made of HDPE and PP. **Stiffening rings STRAUB-PG required.**
- Weight of the pipe couplings see separate packing specifications.
- Strip insert is required when gap between pipe ends is excessive, in presence of swelling, vacuum/depression (suction line), or external pressure. Strip inserts are available, under separate order, at additional costs.

## STRAUB-FLEX

### Versatile – connection and compensator in one

The polyvalente, axially flexible coupling for all pipe materials. For gas and water supply, sewage treatment, industrial plants, power plants and shipbuilding. STRAUB-FLEX absorbs noise, vibrations, expansion and contraction.

Working pressure up to 16 / 25 bar  
Outside diameters 48.3 up to 4000 mm  
Temperature range -20°C up to +80°C

Example for order:  
STRAUB-FLEX 1L 76.1, AISI 316 Ti, EPDM, SS

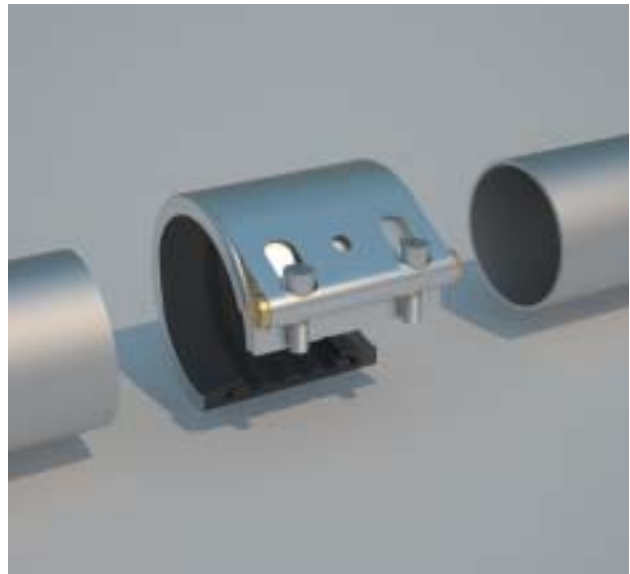

### Rainwatersystem Airport Zurich, Switzerland:

Single manhole with a construction of a stainless steel reduction, used as possibility for servicing.

STRAUB-FLEX 2LS 273.0 mm

STRAUB-FLEX 2LU 427.0 mm



### Changi Water Reclamation Plant, Singapur

STRAUB-FLEX 3X 3065.0 / 3673.0 mm



## Specification STRAUB-FLEX 1L Ø 48.3 – 168.3 mm

Components / Materials	W1	W2	W4	W5
Casing		AISI 304/316 Ti		AISI 316 Ti
Screws		AISI 4135 <sup>o</sup>		AISI 316 L
Bolts		AISI 12L 14, galvanized		AISI 316 L
Strip insert (option)		AISI 316 L / PVDF from 180 mm HDPE		AISI 316 L / PVDF from 180 mm HDPE
Sealing sleeve	Temp.: -20°C up to +80°C			
<b>EPDM</b>	Medium: all qualities of water, waste water, air, solids and chemical products			
Sealing sleeve	Temp.: -20°C up to +80°C			
<b>NBR</b>	Medium: water, gas, oil, fuel and other hydrocarbons			
Sealing sleeve	Temp.: -20°C up to +180°C			
<b>VITON A'</b>	Medien: Medium: ozone, oxygen, acids, gas, oil and fuel (only with strip insert)			

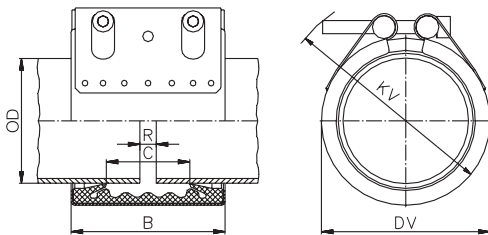

Pipe OD (mm)	Clamping range (mm)	Nominal pressure PN (bar)	Working pressure PS (bar)	Dimensional data				Setting gap between pipe ends R <sub>max</sub> .		Locking bolts		
				B (mm)	C (mm)	DV (mm)	KV (mm)	without	with	torque rate (Nm)	allen head (mm)	thread M...
48.3	47.0 - 49.5	16	25					75	35			
54.0	52.5 - 55.5	16	25	75	35	76	90	5	15	7.5	6	8
57.0	55.5 - 58.5	16	25	75	35	79	95	5	15	7.5	6	8
60.3 <sup>1</sup>	59.0 - 61.5	16	25	75	35	82	95	5	15	7.5	6	8
73.0 <sup>1</sup>	71.5 - 74.5	16	25	94	51	95	117	5	25	7.5	6	8
76.1 <sup>1</sup>	74.5 - 77.5	16	25	94	51	98	122	5	25	7.5	6	8
84.0	82.5 - 85.5	16	24	94	51	106	127	5	25	7.5	6	8
88.9 <sup>1</sup>	87.5 - 90.5	16	24	94	51	111	132	5	25	7.5	6	8
100.6	99.0 - 102.5	16	23	94	51	123	147	5	25	7.5	6	8
101.6	100.0 - 103.5	16	23	94	51	124	147	5	25	7.5	6	8
104.0	102.5 - 105.5	16	22	94	51	126	147	5	25	7.5	6	8
104.8	103.0 - 106.5	16	22	94	51	127	147	5	25	7.5	6	8
108.0	106.5 - 109.5	16	22	94	51	130	152	5	25	7.5	6	8
114.3 <sup>1</sup>	112.5 - 116.0	16	21	94	51	136	157	5	25	7.5	6	8
127.0	125.0 - 129.0	16	19	107	62	149	165	5	35	10	8	10
129.0	127.0 - 131.0	16	18	107	62	151	165	5	35	10	8	10
130.2	128.5 - 132.0	16	18	107	62	152	165	5	35	10	8	10
133.0	131.0 - 135.0	16	16	107	62	155	170	5	35	10	8	10
139.7	138.0 - 141.5	16	16	107	62	162	175	5	35	10	8	10
141.3	139.5 - 143.0	16	16	107	62	163	180	5	35	10	8	10
154.0	152.0 - 156.0	16	16	107	62	176	190	5	35	10	8	10
159.0	157.0 - 161.0	16	16	107	62	181	195	5	35	10	8	10
168.3	166.0 - 170.5	16	16	107	62	190	205	5	35	10	8	10

### Legend:

- W1-W5 according to DIN Standard 86128 (ASTM F1476 / F1548, ISO/NP-15837 / 15838).
- <sup>o</sup> Property class 12.9, Dacromet 500 (zinc-chromate with integrated lubricant).
- PS: Working pressure considering the application loads.

### Remarks:

- Follow fitting / disassembly instructions. Test pressure = 1,5 x PS/PN.
- Admissible **maximum axial movement of the pipes**: 5 mm.
- Weight of the pipe couplings see separate packing specifications.
- Strip insert is required when gap between pipe ends is excessive, in presence of swelling, vacuum/depression (suction line), or external pressure. Strip inserts are available, under separate order, at additional costs.
- Nominal pressure, includes four times safety factor, for applications that require authorisation of classification societies (e.g. ABS, DNV, etc.).

## Specification STRAUB-FLEX 2 Ø 180.0 – 1600.0 mm

Components / Materials	W1	W2	W4	W5
Casing	AISI 1024, hot-dip galv.	AISI 304/316 Ti		AISI 316 Ti
Screws	AISI 4135 <sup>o</sup>	AISI 4135 <sup>o</sup>		AISI 316 L
Bolts	AISI 12L 14, galvanized	AISI 12L 14, galvanized		AISI 316 L
Strip insert (option)	AISI 316 L / HDPE	AISI 316 L / HDPE		AISI 316 L / HDPE
Sealing sleeve	Temp.: -20°C up to +80°C			
<b>EPDM</b>	Medium: all qualities of water, waste water, air, solids and chemical products			
Sealing sleeve	Temp.: -20°C up to +80°C			
<b>NBR</b>	Medium: water, gas, oil, fuel and other hydrocarbons			

L-, LS-, and LU-version in W2 or W5. H- and XS-version in W1.

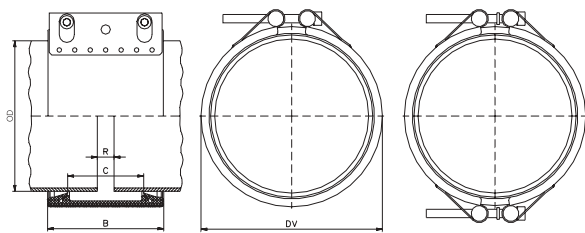

DV = Outside diameter of the braced pipe coupling = OD + 27 mm  
 B = Width of the pipe coupling  
 FLEX 2L = 138 mm  
 FLEX 2LS = 139 mm  
 FLEX 2LU = 141 mm  
 FLEX 2H = 142 mm  
 FLEX 2XS = 148 mm  
 C = Distance between sealing lips = 91 mm  
 R<sub>max.</sub> = Setting gap between pipe ends  
 with strip insert = 35 mm  
 without strip insert = 10 mm

Pipe OD (mm)	Clamping range (mm)	Working pressure					Torque rate					Locking bolts		
		FLEX 2					FLEX 2					FLEX 2		
		L PS (bar)	LS PS (bar)	LU PS (bar)	H PS (bar)	XS PS (bar)	L (Nm)	LS (Nm)	LU (Nm)	H (Nm)	XS (Nm)	L/ LS	LU/ H	XS
180.0	178 - 182	12.0	16.5	25.0	-		10	15	50	-				
200.0	198 - 202	11.0	15.0	25.0	-		10	15	30	-				
219.1	217 - 222	10.0	13.5	25.0	-		10	15	30	-				
250.0	248 - 253	9.0	12.0	24.0	-		10	15	30	-				
267.0	264 - 270	8.0	11.0	22.5	-		15	15	30	-				
273.0	270 - 276	8.0	11.0	22.0	25.0		15	15	30	30				
304.0	301 - 307	7.0	10.0	19.5	25.0		15	20	30	30				
323.9	321 - 327	7.0	9.5	18.5	25.0		15	20	30	30				
355.6	353 - 358	6.0	8.5	17.0	25.0		15	20	30	30				
406.4	404 - 409	5.5	7.5	15.0	22.0	25.0	20	20	30	40	120			
457.2	454 - 460	5.0	6.5	13.0	19.0	25.0	20	20	40	40	120			
508.0	505 - 511	4.5	6.0	12.0	17.0	25.0	20	25	40	40	120	2 (4 <sup>2</sup> )	2 (4 <sup>2</sup> )	2
558.8	556 - 562	4.0	5.5	10.5	16.0	25.0	25	25	40	50	140	x M10	x M12	x M20
609.6	606 - 613	3.5	5.0 <sup>2</sup>	10.0	14.0	25.0	25	25	40	50	140	with	with	with
711.2	708 - 715	-	4.0 <sup>2</sup>	8.5	12.0	25.0	-	30	50	50	140	socket	socket	socket
762.0	758 - 766	-	4.0 <sup>2</sup>	8.0	12.0	23.5	-	30	50	60	160	head	head	head
812.8	809 - 817	-	3.5 <sup>2</sup>	7.5	11.0	22.0	-	30	50	60	160	8 mm	10 mm	17 mm
914.4	910 - 918	-	3.5 <sup>2</sup>	6.5	10.0	20.0	-	35	60	60	160			
1016.0	1012 - 1020	-	3.0 <sup>2</sup>	6.0	9.0	18.0	-	35	60	70	160			
1117.6	1114 - 1122	-	2.5 <sup>2</sup>	5.5	8.0	16.0	-	40	70	70	180			
1219.2	1215 - 1224	-	2.5 <sup>2</sup>	5.0 <sup>2</sup>	7.0 <sup>2</sup>	15.0	-	40	70	80	180			
1320.8	1316 - 1325	-	2.5 <sup>2</sup>	4.5 <sup>2</sup>	7.0 <sup>2</sup>	-	-	45	60	70	-			
1422.4	1418 - 1427	-	2.0 <sup>2</sup>	4.0 <sup>2</sup>	6.0 <sup>2</sup>	-	-	45	60	70	-			
1524.0	1519 - 1529	-	2.0 <sup>2</sup>	4.0 <sup>2</sup>	6.0 <sup>2</sup>	-	-	45	70	80	-			
1600.0	1595 - 1605	-	2.0 <sup>2</sup>	4.0 <sup>2</sup>	6.0 <sup>2</sup>	-	-	50	70	80	-			

Available for all pipe sizes from 180 up to 1600 mm

### Legend:

- W1-W5 according to DIN Standard 86128 (ASTM F1476 / F1548, ISO/NP-15837 / 15838).

<sup>o</sup> Property class 12.9, Dacromet 500 (zinc-chromate with integrated lubricant).

<sup>2</sup> Casing also in two halves.

### Remarks:

- Follow fitting / disassembly instructions. Test pressure = 1,5 x PS.

- Admissible maximum axial movement of the pipes: 10 mm.

- Weight of the pipe couplings see separate packing specifications.

- Strip insert is required when gap between pipe ends is excessive, in presence of swelling, vacuum/depression (suction line), or external pressure.

Strip inserts are available, under separate order, at additional costs.

## Specification STRAUB-FLEX 3 Ø 558.8 – 2032.0 mm

Components / Materials	W1	W2	W4	W5
Casing	AISI 1024, hot-dip galv.	AISI 304/316 Ti		AISI 316 Ti
Screws	AISI 4135 <sup>0</sup>	AISI 4135 <sup>0</sup>		AISI 316 L
Bolts	AISI 12L 14, galvanized	AISI 12L 14, galvanized		AISI 316 L
Strip insert (option)	AISI 316 L / HDPE	AISI 316 L / HDPE		AISI 316 L / HDPE
Sealing sleeve	Temp.: -20°C up to +80°C			
<b>EPDM</b>	Medium: all qualities of water, waste water, air, solids and chemical products			
Sealing sleeve	Temp.: -20°C up to +80°C			
<b>NBR</b>	Medium: water, gas, oil, fuel and other hydrocarbons			

LS-version in W2 or W5. H- and X-version in W1.

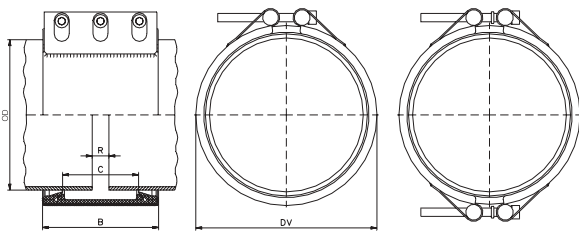

DV = Outside diameter of the braced pipe coupling = OD + 38 mm  
 B = Width of the pipe coupling  
 FLEX 3LS = 210 mm  
 FLEX 3H = 212 mm  
 FLEX 3X = 218 mm  
 C = Distance between sealing lips = 127 mm  
 R<sub>max.</sub> = Setting gap between pipe ends  
 with strip insert = 60 mm  
 without strip insert = 15 mm

Pipe OD (mm)	Clamping (mm)	Working pressure			Torque rate			Locking bolts		
		FLEX 3			FLEX 3			FLEX 3		
		LS PS (bar)	H PS (bar)	X PS (bar)	LS (Nm)	H (Nm)	X (Nm)	LS	H	X
558.8	555 - 562	7.0	19.0	25	40	40	90			
609.6	606 - 613	6.5	17.0	25	40	60	90			
711.2	707 - 715	5.5	15.0	25	40	60	90			
762.0	758 - 766	5.0	14.0	25	40	60	90			
812.8	809 - 817	5.0	13.0	25	50	60	110			
914.4	910 - 918	4.5	11.5	23	50	80	110			
1016.0	1012 - 1020	4.0	10.5	20	50	80	125			
1117.6	1113 - 1122	3.5	9.5	18	50	80	125	3 (6°)	3 (6°)	3 x
1219.2	1215 - 1224	3.5 <sup>2</sup>	8.5 <sup>2</sup>	17 <sup>2</sup>	50	100	140	x M12	x M16	M20
1320.8	1316 - 1325	3.0 <sup>2</sup>	8.0 <sup>2</sup>	16 <sup>2</sup>	60	100	140	with	with	with
1422.4	1418 - 1427	3.0 <sup>2</sup>	7.5 <sup>2</sup>	15 <sup>2</sup>	60	100	160	socket	socket	socket
1524.0	1519 - 1529	2.5 <sup>2</sup>	7.0 <sup>2</sup>	14 <sup>2</sup>	60	100	160	head	head	head
1625.6	1621 - 1631	2.5 <sup>2</sup>	6.5 <sup>2</sup>	13 <sup>2</sup>	60	120	180	10 mm	14 mm	17 mm
1727.2	1722 - 1732	2.5 <sup>2</sup>	6.0 <sup>2</sup>	12 <sup>2</sup>	60	120	180			
1828.8	1824 - 1834	2.0 <sup>2</sup>	5.5 <sup>2</sup>	11 <sup>2</sup>	70	120	200			
1930.4	1925 - 1935	2.0 <sup>2</sup>	5.5 <sup>2</sup>	11 <sup>2</sup>	70	140	200			
2032.0	2027 - 2037	2.0 <sup>2</sup>	5.0 <sup>2</sup>	10 <sup>2</sup>	70	140	220			

Available for all pipe sizes from 558 up to 2032 mm

**Legend:**

- W1-W5 according to DIN Standard 86128 (ASTM F1476 / F1548, ISO/NP-15837 / 15838).
- <sup>0</sup> Property class 12.9, Dacromet 500 (zinc-chromate with integrated lubricant).
- <sup>2</sup> Casing also in two halves.

**Remarks:**

- Follow fitting / disassembly instructions.
- Test pressure = 1,5 x PS.
- Admissible maximum axial movement of the pipes: 15 mm.
- Weight of the pipe joints see separate packing specifications.
- Strip insert is required when gap between pipe ends is excessive, in presence of swelling, vacuum/depression (suction line), or external pressure. Strip inserts are available, under separate order, at additional costs.

## STRAUB-OPEN-FLEX

### Opening

The Straub-OPEN-FLEX is available in a number of different versions: jointed, one-piece or two-piece. The specifications and properties are the same as the STRAUB-FLEX. The great advantage of STRAUB-OPEN-FLEX is that it can be fitted to existing pipes in situ, without any need to remove and re-lay the pipes. This makes it the ideal solution for permanent repairs of pipe joints, cracks, etc. Simple and reliable.

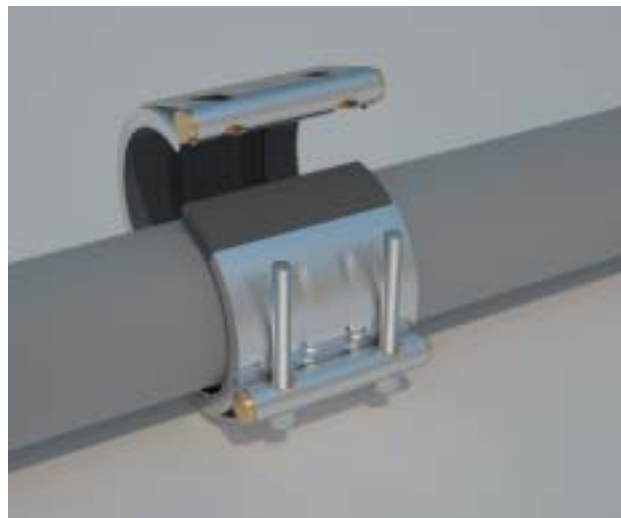

**STRAUB-OPEN-FLEX 1**  
Hinge design



**STRAUB-OPEN-FLEX 2/3**  
slotted design



**STRAUB-OPEN-FLEX 2/3**  
in two halves

### HDPE infed pipe in a water treatment plant

The STRAUB-OPEN-FLEX, used here as an installation and dismantling piece for the slide valve, also acts as a compensator. The slotted casing prevents the pipes from being removed during coupling installation.



Specification STRAUB-OPEN-FLEX 1L Ø 48.3 – 168.3 mm

Components / Materials	W1	W2	W4	W5
Casing		AISI 304/316 Ti		AISI 316 Ti
Screws		AISI 4135 <sup>o</sup>		AISI 316 L
Bolts		AISI 12L 14, galvanized		AISI 316 L
Strip insert (option)		AISI 316 L / PVDF from 180 mm HDPE		AISI 316 L / PVDF from 180 mm HDPE
Sealing sleeve	Temp.: -20°C up to +80°C			
<b>EPDM</b>	Medium: all qualities of water, waste water, air, solids and chemical products			
Sealing sleeve	Temp.: -20°C up to +80°C			
<b>NBR</b>	Medium: water, gas, oil, fuel and other hydrocarbons			

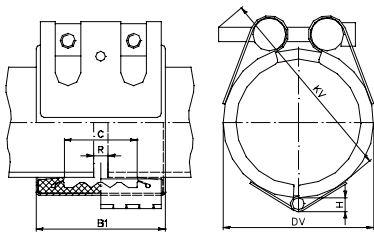

Hinge (H) =	OD 48.3 – 60.3:	7.0 mm
	OD 73.0 – 114.3:	9.0 mm
	OD 127.0 – 168.3:	9.5 mm

Pipe OD (mm)	Clamping range (mm)	Nominal pressure PN (bar)	Dimensional data				Setting gap between pipe ends R <sub>max</sub>		Locking bolts		
			B (mm)	C (mm)	DV (mm)	KV (mm)	without strip insert (mm)	with strip insert (mm)	torque rate (Nm)	allen head (mm)	thread M...
48.3	47.0 - 49.5	16	75	35	70	85	5	15	7.5	6	8
54.0	52.5 - 55.5	16	75	35	76	90	5	15	7.5	6	8
57.0	55.5 - 58.5	16	75	35	79	95	5	15	7.5	6	8
60.3	59.0 - 61.5	16	75	35	82	95	5	15	7.5	6	8
73.0	71.5 - 74.5	16	94	51	95	117	5	25	10	6	8
76.1	74.5 - 77.5	16	94	51	98	122	5	25	10	6	8
84.0	82.5 - 85.5	16	94	51	106	127	5	25	10	6	8
88.9	87.5 - 90.5	16	94	51	111	132	5	25	10	6	8
100.6	99.0 - 102.5	16	94	51	123	147	5	25	10	6	8
101.6	100.0 - 103.5	16	94	51	124	147	5	25	10	6	8
104.0	102.5 - 105.5	16	94	51	126	147	5	25	10	6	8
104.8	103.0 - 106.5	16	94	51	127	147	5	25	10	6	8
108.0	106.5 - 109.5	16	94	51	130	152	5	25	10	6	8
114.3	112.5 - 116.0	16	94	51	136	157	5	25	10	6	8
127.0	125.0 - 129.0	16	107	62	149	165	5	35	12	8	10
129.0	127.0 - 131.0	16	107	62	151	165	5	35	12	8	10
130.2	128.5 - 132.0	16	107	62	152	165	5	35	12	8	10
133.0	131.0 - 135.0	16	107	62	155	170	5	35	12	8	10
139.7	138.0 - 141.5	16	107	62	162	175	5	35	12	8	10
141.3	139.5 - 143.0	16	107	62	163	180	5	35	12	8	10
154.0	152.0 - 156.0	16	107	62	176	190	5	35	12	8	10
159.0	157.0 - 161.0	16	107	62	181	195	5	35	12	8	10
168.3	166.0 - 170.5	16	107	62	190	205	5	35	12	8	10

Legend:

- W1-W5 according to DIN Standard 86128 (ASTM F1476 / F1548, ISO/NP-15837 / 15838).
- <sup>o</sup> Property class 12.9, Dacromet 500 (zinc-chromate with integrated lubricant).

Remarks:

- Follow fitting / disassembly instructions.
- Test pressure = 1,5 x PN.
- **Admissible maximum axial movement of the pipes: 5 mm.**
- Weight of the coupling see separate packing specifications.
- Strip insert is required when gap between pipe ends is excessive, in presence of swelling, vacuum/depression (suction line), or external pressure. Strip inserts are available, under separate order, at additional costs.

## Specification STRAUB-OPEN-FLEX 2 Ø 180.0 – 1219.2 mm

Components / Materials	W1	W2	W4	W5
Casing	AISI 1024, hot-dip galv.	AISI 304/316 Ti		AISI 316 Ti
Screws	AISI 4135 <sup>0</sup>	AISI 4135 <sup>0</sup>		AISI 316 L
Bolts	AISI 12L 14, galvanized	AISI 12L 14, galvanized		AISI 316 L
Strip insert (option)	AISI 316 L / HDPE	AISI 316 L / HDPE		AISI 316 L / HDPE
Sealing sleeve	Temp.: -20°C up to +80°C			
<b>EPDM</b>	Medium: all qualities of water, waste water, air, solids and chemical products			
Sealing sleeve	Temp.: -20°C up to +80°C			
<b>NBR</b>	Medium: water, gas, oil, fuel and other hydrocarbons			

L-, LS-, and LU-version in W2 or W5. H-version in W1.

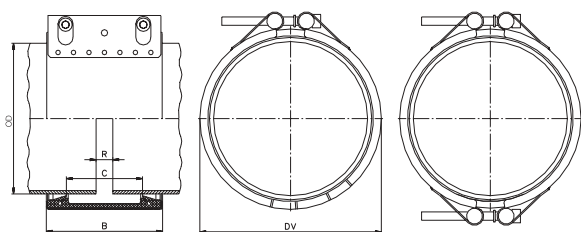

DV = Outside diameter of the braced pipe coupling = OD + 27 mm  
 B = Width of the pipe coupling  
 OPEN-FLEX 2L = 138 mm  
 OPEN-FLEX 2LS = 139 mm  
 OPEN-FLEX 2LU = 141 mm  
 OPEN-FLEX 2H = 142 mm  
 C = Distance between sealing lips = 91 mm  
 B<sub>max.</sub> = Setting gap between pipe ends  
 with strip insert = 35 mm  
 without strip insert = 10 mm

Pipe OD (mm)	Clamping range (mm)	Working pressure				Torque rate				Locking bolts	
		OPEN-FLEX 2				OPEN-FLEX 2				OPEN-FLEX 2	
		L PS (bar)	LS PS (bar)	LU PS (bar)	H PS (bar)	L (Nm)	LS (Nm)	LU (Nm)	H (Nm)	L/LS	LU/ H
180.0	178 - 182	12.0	16.0	-	-	10	15	-	-		
200.0	198 - 202	11.0	15.0	-	-	10	15	-	-		
219.1	217 - 222	10.0	13.5	16.0 <sup>2</sup>	-	10	15	30	-		
250.0	248 - 253	9.0	12.0	16.0 <sup>2</sup>	-	10	15	30	-		
267.0	264 - 270	8.0	11.0	16.0 <sup>2</sup>	-	15	15	30	-		
273.0	270 - 276	8.0	11.0	16.0 <sup>2</sup>	16.0 <sup>2</sup>	15	15	30	30		
304.0	301 - 307	7.0	10.0	16.0 <sup>2</sup>	16.0 <sup>2</sup>	15	20	30	30		
323.9	321 - 327	7.0	9.5	16.0 <sup>2</sup>	16.0 <sup>2</sup>	15	20	30	30		
355.6	353 - 358	6.0	8.5	16.0 <sup>2</sup>	16.0 <sup>2</sup>	15	20	30	30		
406.4	404 - 409	5.5	7.5	15.0 <sup>2</sup>	16.0 <sup>2</sup>	20	20	30	40	2	2 (4 <sup>2</sup> )
457.2	454 - 460	5.0	6.5	13.0 <sup>2</sup>	16.0 <sup>2</sup>	20	20	40	40	x M10	x M12
508.0	505 - 511	4.5	6.0	10.0 <sup>2</sup>	16.0 <sup>2</sup>	20	25	40	40	with	with
558.8	556 - 562	4.0	5.5	9.0	16.0 <sup>2</sup>	25	25	40	50	socket head	socket head
609.6	606 - 613	3.5	5.0	8.0	14.0 <sup>2</sup>	25	25	40	50	8 mm	10 mm
711.2	707 - 715	-	4.0	7.0	12.0 <sup>2</sup>	-	30	50	50		
762.0	758 - 766	-	4.0	6.5	12.0 <sup>2</sup>	-	30	50	60		
812.8	809 - 817	-	3.5	6.0	11.0 <sup>2</sup>	-	30	50	60		
914.4	910 - 918	-	3.5	5.5	10.0 <sup>2</sup>	-	35	60	60		
1016.0	1012 - 1020	-	3.0	5.0	9.0 <sup>2</sup>	-	35	60	70		
1117.6	1114 - 1122	-	2.5	4.5	8.0 <sup>2</sup>	-	40	70	70		
1219.2	1215 - 1223	-	2.5	4.0	7.0 <sup>2</sup>	-	40	70	80		

Available for all pipe sizes from 180 up to 1219 mm

### Legend:

- W1-W5 according to DIN Standard 86128 (ASTM F1476 / F1548, ISO/NP-15837 / 15838).

<sup>0</sup> Property class 12.9, Dacromet 500 (zinc-chromate with integrated lubricant).

<sup>2</sup> Casing in two halves.

### Remarks:

- Follow fitting / disassembly instructions.

- Test pressure = 1,5 x PS.

- **Admissible maximum axial movement of the pipes: 10 mm.**

- Weight of the repair clamps see separate packing specifications.

- Strip insert is required when gap between pipe ends is excessive, in presence of swelling, vacuum/depression (suction line), or external pressure. Strip inserts are available, under separate order, at additional costs.

Specification STRAUB-OPEN-FLEX 3 Ø 558.8 – 2032.0 mm

Components / Materials	W1	W2	W4	W5
Casing	AISI 1024, hot-dip galv.	AISI 304/316 Ti		AISI 316 Ti
Screws	AISI 4135 <sup>0</sup>	AISI 4135 <sup>0</sup>		AISI 316 L
Bolts	AISI 12L 14, galvanized	AISI 12L 14, galvanized		AISI 316 L
Strip insert (option)	AISI 316 L / HDPE	AISI 316 L / HDPE		AISI 316 L / HDPE
Sealing sleeve	Temp.: -20°C up to +80°C			
<b>EPDM</b>	Medium: all qualities of water, waste water, air, solids and chemical products			
Sealing sleeve	Temp.: -20°C up to +80°C			
<b>NBR</b>	Medium: water, gas, oil, fuel and other hydrocarbons			

LS-version in W2 or W5. H-version in W1.

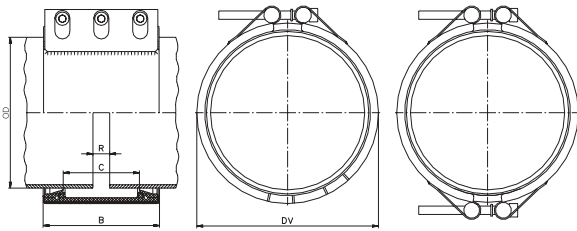

DV = Outside diameter of the braced pipe coupling = OD + 38 mm  
 B = Width of the pipe coupling  
 OPEN-FLEX 3LS = 210 mm  
 OPEN-FLEX 3H = 212 mm  
 C = Distance between sealing lips = 127 mm  
 R<sub>max.</sub> = Setting gap between pipe ends  
 with strip insert = 60 mm  
 without strip insert = 15 mm

Pipe OD (mm)	Clamping range (mm)	Working pressure OPEN-FLEX 3		Torque rate OPEN-FLEX 3		Locking bolts OPEN-FLEX 3	
		LS PS (bar)	H PS (bar)	LS (Nm)	H (Nm)	LS	H
558.8	555 - 562	7.0	-	40	-		
609.6	606 - 613	6.5	-	40	-		
711.2	707 - 715	5.5	-	40	-		
762.0	758 - 766	5.0	-	40	-		
812.8	809 - 817	5.0	-	50	-		
914.4	910 - 918	4.5	-	50	-		
1016.0	1012 - 1020	4.0	-	50	-		
1117.6	1113 - 1122	3.5	-	50	-		
1219.2	1215 - 1224	3.5 <sup>2</sup>	8.5 <sup>2</sup>	50	60	3 (6°)	6°
1320.8	1316 - 1325	3.0 <sup>2</sup>	8.0 <sup>2</sup>	50	60	x M12	x M16
1422.4	1418 - 1427	3.0 <sup>2</sup>	7.5 <sup>2</sup>	60	70	with	with
1524.0	1519 - 1529	2.5 <sup>2</sup>	7.0 <sup>2</sup>	60	70	socket head	socket head
1625.6	1621 - 1631	2.5 <sup>2</sup>	6.5 <sup>2</sup>	60	80	10 mm	14 mm
1727.2	1722 - 1732	2.5 <sup>2</sup>	6.0 <sup>2</sup>	60	80		
1828.8	1824 - 1834	2.0 <sup>2</sup>	5.5 <sup>2</sup>	70	90		
1930.4	1925 - 1936	2.0 <sup>2</sup>	5.5 <sup>2</sup>	70	90		
2032.0	2027 - 2037	2.0 <sup>2</sup>	5.0 <sup>2</sup>	70	100		

Available for all pipe sizes from 558 up to 2032 mm

Legend:

- W1-W5 according to DIN Standard 86128 (ASTM F1476 / F1548, ISO/NP-15837 / 15838).
- <sup>0</sup> Property class 12.9, Dacromet 500 (zinc-chromate with integrated lubricant).
- <sup>2</sup> Casing in two halves.

Remarks:

- Follow fitting / disassembly instructions.
- Test pressure = 1,5 x PS.
- **Admissible maximum axial movement of the pipes: 15 mm.**
- Weight of the repair clamps see separate packing specifications.
- Strip insert is required when gap between pipe ends is excessive, in presence of swelling, vacuum/depression (suction line), or external pressure. Strip inserts are available, under separate order, at additional costs.

## OPTIONS

### **STRAUB-OPEN-FLEX GT** **The wrap-around coupling with side outlet**

The STRAUB-OPEN-FLEX GT combines all the advantages of the original, with the added benefit of a side outlet. A simple, low-cost solution for a wide range of applications, including venting, sample-taking, measurement points and system extensions.

Connection possibilities with threaded fittings and STRAUB couplings.

- Available for all STRAUB-OPEN-FLEX 1 from 73.0 mm (STRAUB-METAL-GRIP GT on request)



### **STRAUB-STEP-FLEX** **For connecting pipes of different diameters**

Not pull-out resistant coupling for joining smooth-ended pipes with diameter differences up to 27 mm.

The dimensions and properties of STRAUB-STEP-FLEX are the same as those of STRAUB-FLEX 2.

- Available for outside diameters 180–1600 mm
- Working pressure and temperature on request
- Restraining harness on request

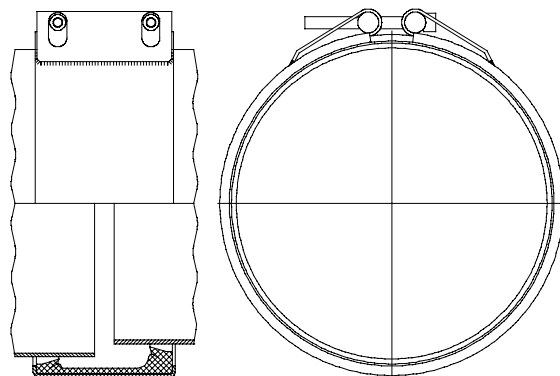

### **STRAUB-GRIP-L FLAMSTOP** **Fireproof**

The STRAUB-GRIP-L FLAMSTOP combines an original STRAUB-GRIP-L coupling with a stainless steel fireproof sleeve. In conjunction with an integrated, high-grade woven ceramic fibre, it withstands temperatures of 900° C for more than an hour.

Initially conceived to meet space, weight and time requirements in naval shipbuilding.

Designed to meet SOLAS fire, smoke and toxicity specifications.

Complies with ISO 19921/22 and German VDS Directives.

- Available for outside diameters 26.9–219.1 mm
- Other diameters on request



# Accessories

## Electrical conductivity clips

STRAUB-FLEX couplings do not provide electrical conductivity. Electrical conductivity can be ensured by the application of special electrical conductivity clips which have to be fitted into the coupling (Straub Accessory). Our Clip-system is proofed by the Swiss Electrotechnical Association (SEV) with relevant clauses of SEV 04 ATEX 0167 (EN 1127-1: 1997 and EN 13463-1: 2001).

Also in shipbuilding our electrical conductivity clips are approved. See for instance the American Bureau of Shipping (ABS) certificate No. 01-MF15543-X. STRAUB-electrical conductivity clips are available starting from diameter 73 mm.

**Benefits:**

Explosion protection

Corrosion protection

Electroconductive connection of GRP pipes

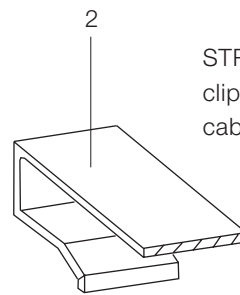

STRAUB-electrical conductivity clips instead of external cable connectors.

- 1 = Casing
- 2 = Conductivity clip
- 3 = Sealing sleeve

**Waste water treatment plant Frankfurt-Sindlingen**  
Electrical conductivity through external cable connector (made on site) STRAUB-FLEX 2LS used as main joint.

## STRAUB-OPEN-FLEX fitting tools



tensioning belt

fitting plier



## Torque wrench



## Strip inserts

Strip inserts to be used if required. Strip inserts protect the sealing sleeve against mechanical or chemical damage in the pipe end area. Strip inserts required for excessive distance between pipe ends, axial movement (expansion, contraction) combined with angular deflection, axial misalignment, vacuum/depression (suction line), fuel and combustibles or that may cause swelling. Prefitting of strip inserts for all types of couplings possible. Strip insert quality depends to the medium.

T-profile inserts prevent drifting of coupling from it's centre position if excessive axial movement occurs. STRAUB couplings do not slip if axial movement stays within STRAUB limits (see page 29, pt. 5).



Pipe Joint Type / Dimension	Stainless Steel	Plastic		T-Profile	
	1.4435	PVDF	HDPE	HDPE	PVDF
<b>STRAUB-FLEX 1 / OPEN-FLEX 1</b>	X	X			X
<b>STRAUB-FLEX 2 / OPEN-FLEX 2</b>	X		X	X	
<b>STRAUB-FLEX 3 / OPEN-FLEX 3</b>	X		X	X	
<b>STRAUB-GRIP-L 180.0-609.6 mm</b>	X		X		
<b>STRAUB-METAL-GRIP</b>	X	X			
<b>STRAUB-PLAST-GRIP</b>	X	X			
<b>STRAUB-COMBI-GRIP</b>	X	X			

Stainless steel 1.4435 (V4A) / 316 Ti

HDPE = High density Polyethylene

PVDF = Sygef -60/+150° C (Polyvinylidenfluorid)

## STRAUB material specifications

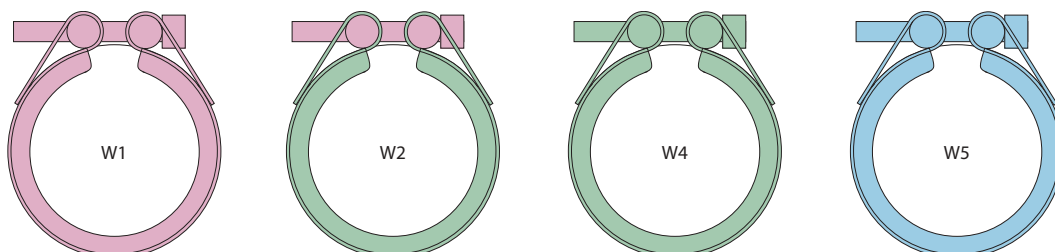

Components	W1 (MG, FLEX, OPEN-FLEX)		W2 (MG, PG, CG, FLEX, OPEN-FLEX)		W4 (MG, PG, CG)		W5 (GRIP-L, FLEX, OPEN-FLEX)	
	DIN	AISI	DIN	AISI	DIN	AISI	DIN	AISI
Casing	1.0570, galvanized	1024	1.4301	304	1.4301	304	1.4571	316 Ti
Screws	1.7220	4135	1.7220	4135	1.4404 / 1.4435	316 L	1.4404 / 1.4435	316 L
Bolts	1.0737, galvanized	12L14	1.0737, galvanized	12L14	1.4404 / 1.4435	316 L	1.4404 / 1.4435	316 L
Anchoring ring	1.4310	301	1.4310 / 1.4301	301	1.4310 / 1.4301	301	1.4310	301
Strip insert (option)	1.4435	316 L	1.4435	316 L	1.4435	316 L	1.4435	316 L

## Dimensions and minimum wall thickness



Pipe OD		Nominal diameter		Minimum wall thickness	
Metric (mm)	IPS (inch)	Metric (DN)	IPS (Nom)	Stainless steel STRAUB-GRIP-L STRAUB-METAL-GRIP	CuNi10 Fe (DIN) CuNi10Mn1Fe (ISO) STRAUB-GRIP-L
				(mm)	(mm)
26.9	1.050	20	3/4	1.5	1.5
30.0	1.180	25	1.2	1.5	1.5
33.7	1.325	25	1	1.5	2.0
38.0	1.495	32	1.5	1.5	2.0
42.4	1.670	32	1 1/4	1.5	2.0
44.5	1.750	40	1.75	1.5	2.0
48.3	1.900	40	1 1/2	1.5	2.0
54.0	2.125	50	2.125	1.5	2.0
57.0	2.245	50	2.25	1.5	2.0
60.3	2.375	50	2	1.5	2.0
66.6	2.625	65	2 1/2	2.0	2.0
70.0	2.756	65	2 1/2	2.0	2.0
73.0	2.875	65	2 1/2	2.0	2.0
76.1	(3.000)	65	(30.D.)	2.0	2.0
79.5	3.125	65	3	2.0	2.0
84.0	3.305	80	3.3	2.0	2.0
88.9	3.500	80	3	2.0	2.0
100.6	3.960	80	(3)	2.0	2.3
101.6	(4.000)	90	(3 1/2)	2.0	2.3
104.0	4.095	100	4.1	2.0	2.3
104.8	4.125	100	(4)	2.0	2.3
108.0	4.250	100	4 1/4	2.0	2.3
114.3	4.500	100	4	2.0	2.3
127.0	5.000	100	4 1/2	2.3	3.0
129.0	5.080	125	5	2.3	3.0
130.2	5.125	125	(5)	2.3	3.0
131.0 <sup>3</sup>				3.0	
133.0	5.235	125	5 1/4	2.3	3.0
139.7	(5.500)	125	(5 1/2)	2.3	3.0
141.3	5.565	125	5	2.3	3.0
154.0	6.065	150	6.1	2.3	3.0
155.0 <sup>3</sup>				2.5	
159.0	6.260	150	6 1/4	2.3	3.0
168.3	6.625	150	6	2.3	3.5
193.7	7.625	200	7.6	3.0	3.5
206.0 <sup>3</sup>				3.0	
219.1	8.625	200	8	3.0	3.5
				<b>only STRAUB-GRIP-L **</b>	
244.5	9.625	225	9	3.0	4.5
256.0 <sup>3</sup>				3.0	
267.0	10.510	250	10.5	3.0	4.5
273.0	10.750	250	10	3.0	5.0
306.0 <sup>3</sup>				3.0	
323.9	12.750	300	12	3.0	5.5
355.6	14.000	350	14	3.0	6.0
406.4	16.000	400	16	3.0	8.0
457.2	18.000	450	18	3.0	9.0
508.0	20.000	500	20	3.0	10.0
558.8	22.000	550	22	3.0	10.0
609.6	24.000	600	24	3.0	12.0

dark grey = standard diameters

\*\* For STRAUB-METAL-GRIP from ø 244.5 mm contact factory.

<sup>3</sup> Standard pipe dimension for stainless steel. (outer diameter related to the wall thickness).

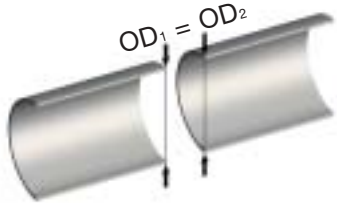
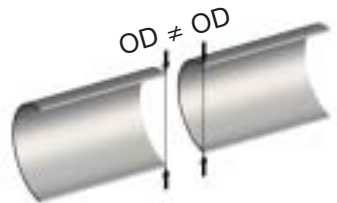
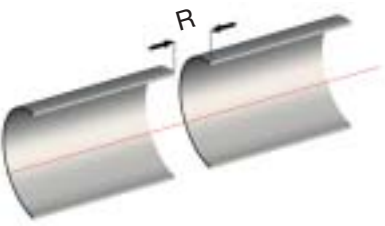
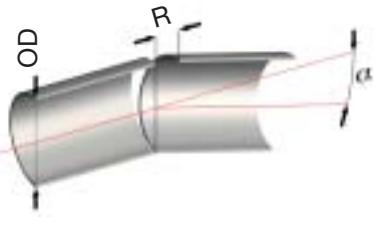
## Fitting tolerances

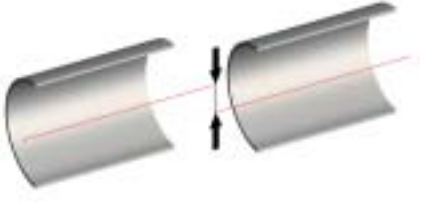
1		<p><b>Clamping range</b> Connecting two pipes with equal outside diameter.</p>														
2		<p><b>Different diameters</b> Connecting two pipes with different outside diameters.</p>														
3		<p><b>Setting gap between pipe ends R</b> for stainless steel pipes above 114.3 mm min. setting gap of 5 mm recommended.</p>														
4		<p><b>Angular deflection <math>\alpha</math></b> Setting gap between pipe ends due to angular deflection. Do not add 3 and 4.</p>														
5		<p><b>Axial movement <math>\Delta</math></b> STRAUB-FLEX/OPEN-FLEX couplings act as expansion joints within stated limits.</p> <p>Reaction forces FLEX couplings:</p> <table border="1" data-bbox="810 1758 1444 1825"> <thead> <tr> <th><math>\varnothing</math> in mm</th> <th>101.6</th> <th>168.0</th> <th>219.1</th> <th>355.6</th> <th>558.8</th> <th>812.8</th> </tr> </thead> <tbody> <tr> <td>N</td> <td>3800</td> <td>4800</td> <td>5600</td> <td>7300</td> <td>9800</td> <td>12500</td> </tr> </tbody> </table>	$\varnothing$ in mm	101.6	168.0	219.1	355.6	558.8	812.8	N	3800	4800	5600	7300	9800	12500
$\varnothing$ in mm	101.6	168.0	219.1	355.6	558.8	812.8										
N	3800	4800	5600	7300	9800	12500										
6		<p><b>Axial misalignment</b> Connecting of two pipes with axial misalignment. Maximum allowed 1% of outside diameter (max. 3 mm)</p>														

## Approximate values for fitting tolerances

STRAUB TYPE	Pipe OD  OD-Range mm	1	2	3	
		Clamping range per OD	Different diameters	Setting gap between pipe ends R <sub>max</sub>	
		+/- mm / %	mm / %	without Strip insert mm	with mm
<b>METAL-GRIP</b>	33.7 - 54.0	0.5	2	5	15
	57.0 - 88.9	1.0%	2	10	25
	104.0 - 114.3	1.0%	2%	10	25
	133.0 / 139.7 / 159.0 / 168.3	1.0%	2%	15	30
	129.0 / 154.0 / 219.1 / 273.0	1.0%	2%	15	35
323.9 - 609.6	1.0%	6	15	35	
<b>GRIP-L</b>	26.9 - 33.7	1.0%	2	5	5
	38.0 - 48.3	1.0%	2	5	10
	54.0 - 60.3 / 84.0	1.0%	2	10	15
	73.0 / 76.1 / 88.9	1.0%	2	10	25
	100.6 - 104.8	1.0%	2%	10	15
	108.0 / 114.3	1.0%	2%	10	25
	154.0	1.0%	2%	10	30
	127.0 - 141.3 / 159.0 - 273.0	1.0%	2%	10	35
304.0 - 609.6	1.0%	6	10	35	
<b>COMBI-GRIP</b>	40.0 / 38.0 - 50.0 / 48.3	0.5 / 0.5	2	5	10
	63.0 / 60.3 - 90.0 / 88.9	1.0 / 1.0	2	10	25
	110.0 / 108.0 - 114.3 / 114.3	1.0 / 2.0	2%	10	25
	140.0 / 139.7 - 160.0 / 159.0	1.5 / 1.5	2%	15	35
<b>PLAST-GRIP</b>	40.0 - 50.0	0.5	2	5	15
	63.0 - 90.0	1.0	2	10	25
	110.0 - 114.3	1.0	2%	10	25
	125.0 - 160.0	1.5	2%	15	35
<b>FLEX 1 / OPEN-FLEX 1</b>	48.3 - 60.3	0.5%	2	5	15
	76.1 - 88.9	1.0%	2	5	25
	100.6 - 114.3	1.0%	2%	5	25
	127.0 - 168.3	1.0%	2%	5	35
<b>FLEX 2 / OPEN-FLEX 2</b>	180.0 - 300.0	1.0%	2%	10	35
	301.0 - 1219.2	3	6	10	35
<b>FLEX 3</b>	558.8 - 2032.0	3	6	15	60
<b>OPEN-FLEX 3</b>	558.8 - 1219.2	3	6	15	60



### 4 Angular deflection

Outside diameter OD mm		α Degree
GRIP	FLEX / OPEN-FLEX	
up to 60.3	up to 60.3	5
from 76.1	from 76.1	4
from 219.1	from 219.1	2

### 5 max. axial movement

STRAUB-Type	Δl mm
FLEX 1 / OPEN-FLEX 1	5
FLEX 2 / OPEN-FLEX 2	10
FLEX 3 / OPEN-FLEX 3	15

## Main range of application

### Industry

Cooling lines  
Lubrication lines  
Utility lines  
Fuel lines  
Penstock lines  
Turbine lines

### Water/Gas

Water lines  
Gas lines  
Wells  
Hydrant lines  
Tank lines  
Sludge lines  
Drainage lines  
Chemical lines  
Airation lines

### Building construction/ groundwork

Sanitary lines  
Fuel lines  
Fire fighting lines  
Ventilation lines

### Shipbuilding/Offshore

Ballast lines  
Fuel lines  
Fire fighting lines  
Vent lines  
Sea water cooling systems

## Coupling selection chart

<b>straub®</b> the original	Pipe material	Operating pressure bar	Outer diameter mm	Key Temperatur EPDM / NBR*	Type of pipe joint
<b>GRIP</b> Axial restraint pipe joint Installation without anchor points	Metal/Metal	67 – 26	30.0 – 219.1	2	<b>METAL-GRIP</b>
		27 – 05	244.5 – 609.6	1	<b>METAL-GRIP</b>
		46 – 16	26.9 – 219.1	1	<b>GRIP-L</b>
		16 – 01	180.0 – 609.6	1	<b>GRIP-L</b>
	Plastic/Metal	16	40/38 – 160 / 159	2	<b>COMBI-GRIP</b>
Plastic/Plastic	16	40.0 – 160.0	2	<b>PLAST-GRIP</b>	
<b>FLEX</b> Pipe joint without axial restraint Installations with anchor points	All pipe materials	25 – 16	48.3 – 168.3	1	<b>FLEX 1L</b>
		25 – 02	180.0 – 1600.0	1	<b>FLEX 2L-2H</b>
		19 – 02	558.8 – 2032.0	1	<b>FLEX 3LS-3H</b>
<b>OPEN-FLEX</b> Wrap-around pipe joint without axial restraint anchor points requested	All pipe materials	16	48.3 – 168.3	1	<b>OPEN-FLEX 1L</b>
		16 – 2,5	180.0 – 1219.2	1	<b>OPEN-FLEX 2L-2H</b>
		07 – 02	558.8 – 2032.0	1	<b>OPEN-FLEX 3LS</b>

\*1: EPDM -20°C TO + 80°C / NBR -20°C TO +80°C  
\*2: EPDM -30°C TO + 100°C / NBR -20°C TO +80°C

## Suitable on different pipe materials

Pipe Materials	METAL-GRIP / GRIP-L	COMBI-GRIP / PLAST-GRIP	FLEX / OPEN-FLEX	Stiffening ring	Remarques
HDPE, PP, Noryl	–	X	X	X	for FLEX pipes must be properly anchored
PVC, ABS, CPVC	X	X	X	–	
GFK (centrefugal and crosswinded pipes)	–	–	X	–	Seal pipe surface at the cutting edge
Asbestos cement (Eternit)	–	–	X	–	
Concrete	–	–	X	–	equalize rough surface with coating or filler
Cast (ductile, grey)	X	X	X	–	
Glas, Ceramic	–	–	X	–	
Copper-Nickel	X	X	X	(X)	soft copper with stiffening ring only, see also page 27
Aluminum	X	X	X	–	

The materials and data in this catalogue are intended to assist the user in the proper selection of Straub Coupling products. Straub Pipe Couplings assumes no responsibility for any damage that might occur as a result of the use of any data, charts or application examples contained herein. All the information contained in this catalog is subject to change by Straub Pipe couplings without notice as a result of product re-designs, product improvements or other reasons.

Straub Pipe Couplings are designed for use under circumstances in which human life is potentially at risk. When considering the use of any product contained herein for special applications, please contact, Straub Werke A.G., Switzerland, or an authorized Straub distributor.

#### **LIABILITY DISCLAIMER**

The information contained herein may include inaccuracies or typographical errors. In addition, changes are periodically made to this information. Straub may make such changes to this information at any time without notice to the user.

Straub Pipe Couplings makes no representations about the suitability of the information contained herein for any purpose. All such information is provided as is without warranty of any kind. Straub Pipe couplings disclaims all warranties with regard to this information. Under no circumstances shall Straub Pipe Couplings be liable for any direct, indirect, punitive, incidental, special or consequential damages arising out of or connected with the use of this information, whether based on contract, tort, strict liability or otherwise, even if Straub Pipe Couplings has been advised of the possibility of damages.